

Contents

1 Product



AR-331(E) AR-331(EF)

2 Terminal Cables

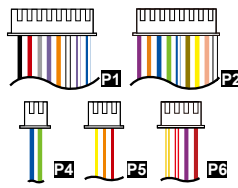

3 Tools

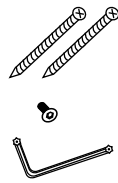

Flat Head Cap Philips
Tapping Screw: 4x20

Security Torx: M3x10

Security Torx Wrenches

4 Accessories

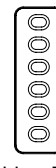

Rubber Pad

5 Option



RJ45 socket



TCP/IP
Module

Installation

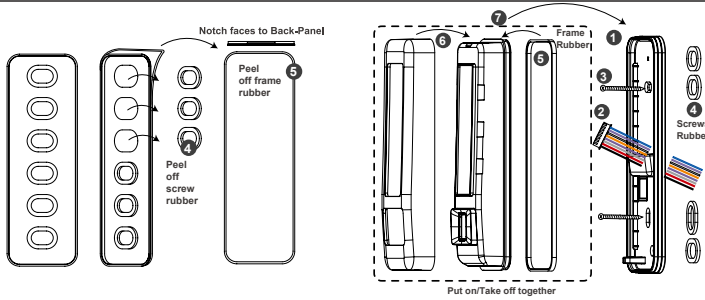

- Peel off screw hole rubbers and frame rubber from rubber pad
- Put screw rubbers on the back side of the mounting plate and pull the cables from the square hole of the mounting plate.
- Put a frame rubber on the frame groove of body
- Connect the terminal cables to the body and attach the body to the mounting plate.
- Assemble the covers with the Allen key and screws (accessories supplied).
- Turn on the power and LED will light and beep will sound.

Front Panel & Indicator

Left LED	Description	Right LED	Description
Blue	Arming / Blue LED Input (Active High)	Green	Power-on/Stand-by /OK
Yellow	Yellow LED Input (Active High)	Red	Error/Alarm

While power on the device, hands off the touch panel for 10 sec. to make sure a successful activation.

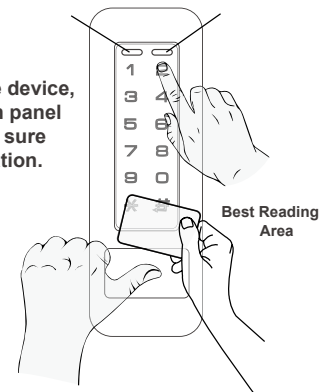

Connector Table

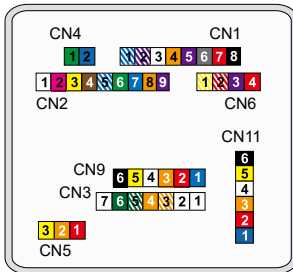

Cable: P1 CN1

Wire Application	Wire	Color	Description
Lock Relay	1	Blue White	(N.O.)DC24V1Amp
	2	Purple White	(N.C.)DC24V1Amp
Common-COM-Point	3	White	(COM)DC24V1Amp
Door Contact	4	Orange	Negative Trigger Input
Exit Switch	5	Purple	Negative Trigger Input
Alarm Relay	6	Gray	Transistor Output Max. 12V/100mA (Open Collector Active Low)
Power	7	Thick Red	DC 12V
	8	Thick Black	DC 0V

Cable: P2 CN2

Wire Application	Wire	Color	Description
DI1	1	White	Reserved
Beeper	2	Pink	Beeper Output 5V/100mA, Low
LED	3	Yellow	Red LED Output 5V/20mA, Max
	4	Brown	Green LED Output 5V/20mA, Max
Door Output	5	Blue White	Transistor Output Max. 12V/100mA (Open Collector Active Low)
Wiegand	6	Thin Green	Wiegand DAT: 0 Input
	7	Thin Blue	Wiegand DAT: 1 Input
WG Door Contact	8	Orange	Negative Trigger Input
WG Exit Switch	9	Purple	Negative Trigger Input

Cable: P3 CN3

Wire Application	Wire	Color	Description
TCP/IP Output	1	---	---
	2	---	---
	3	Orange White	Net - TX+
	4	Orange	Net - TX-
	5	Green White	Net - RX+
	6	Germ	Net - RX-
	7	---	---

Cable: P4 CN4

Wire Application	Wire	Color	Description
RS-485 for Lift Controller	1	Thick Green	RS-485(B-)
	2	Thick Blue	RS-485(A+)

Cable: P5 CN5

Wire Application	Wire	Color	Description
Anti-Tamper Switch	1	Red	N.C.
	2	Orange	COM
	3	Yellow	N.O.

Cable: P6 CN6

Wire Application	Wire	Color	Description
Power	1	Red	DC 12V Output
Security trigger signal	2	Purple	Security trigger signal Output
Arming	3	Red White	Arming Output
Duress	4	Yellow White	Duress Output

Cable: P3 CN9/CN11

Wire Application	Wire	Color	Description
TTL Output	1	Blue	CLK
	2	Red	DC 5V
	3	Orange	RX
	4	White	TE
	5	Yellow	TX
	6	Black	DC 0V

Notice

- 1.Tubing:** The communication wires and power line should NOT be bound in the same conduit or tubing.
- 2.Wire selection:** Use AWG 22-24 Shielded Twist Pair to avoid star wiring.
- 3.Power supply:** Don't equip controller and lock with the same power supply. The power for controller may be unstable when the lock is activating, that may make the controller malfunction.
The standard installation: Door relay and lock use the same power supply, and controller use independent power supply.

Wiring Diagram

Connect to Electric Bolt

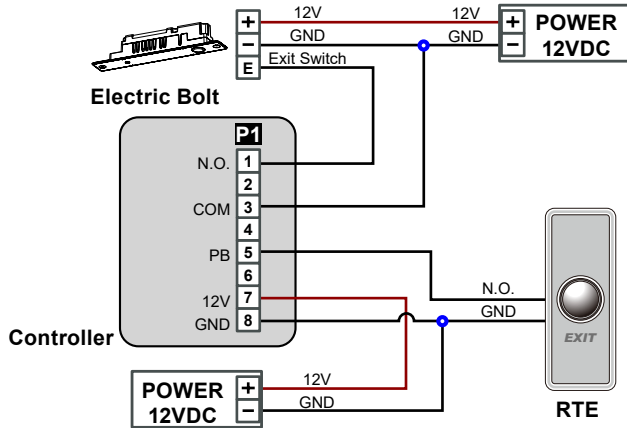

Connect to Magnet Lock

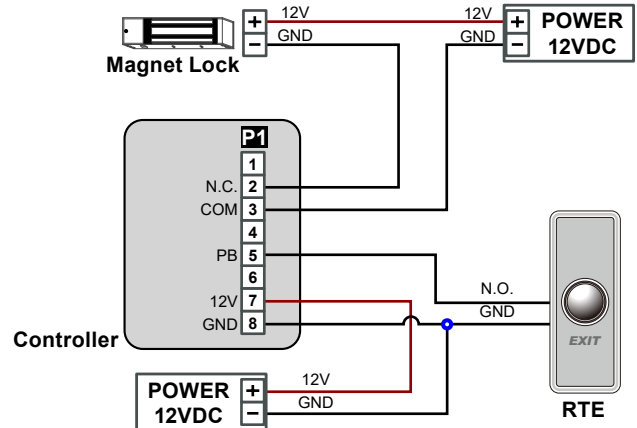

Connect to Electric Strike

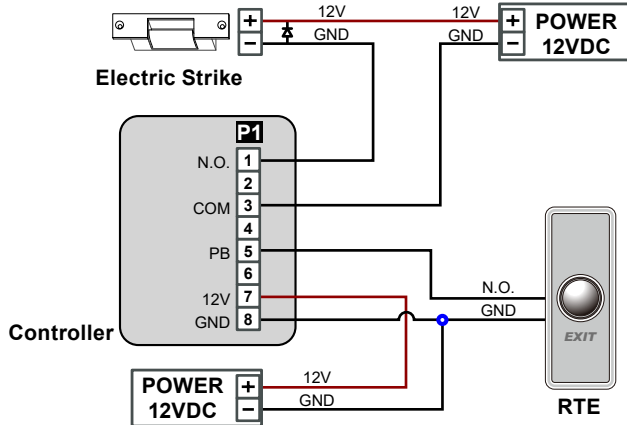

Connect to Door Contact

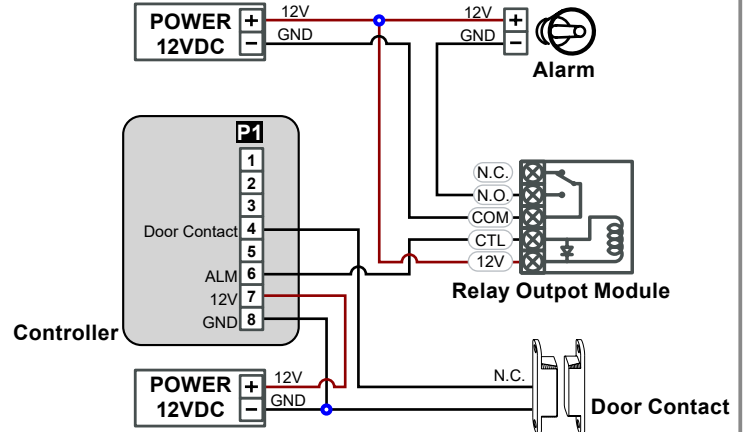

Strengthen security with Digital Relay Board

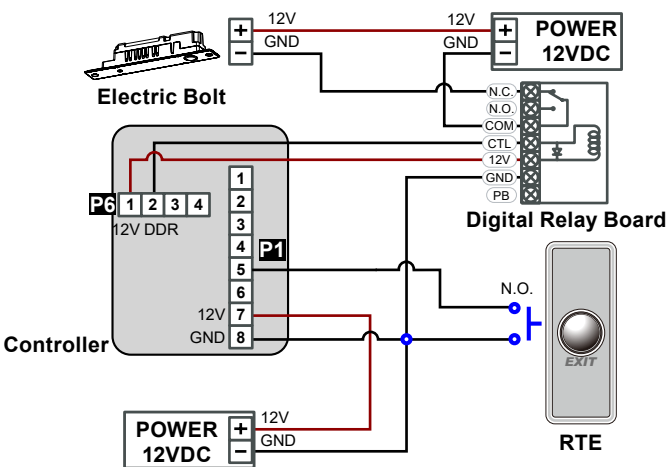

Connect to Reader

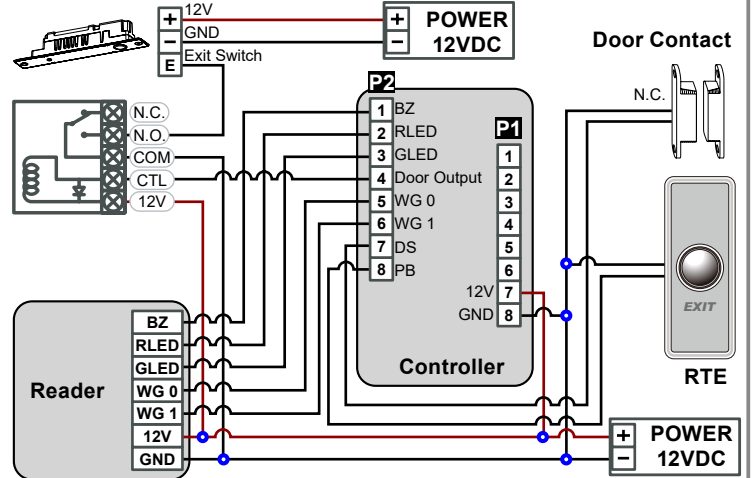

AR-331(E/EF)become WG mode (28 * 016 #)

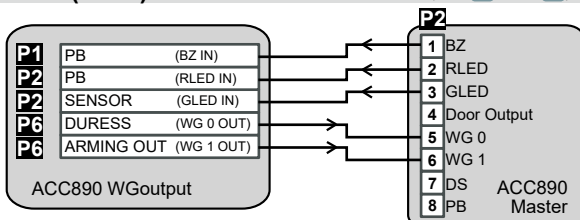

1. When AR-331(E/EF)become WG mode,it can be used with any controllers.
2. AR-331(E/EF)support Anti-pass-back by finger or card.

※Using Rule :

Finger : Both AR-331(EF) Master mode and AR-331(EF) WG mode must store all the same FP data and real or visual card number.

Card : Can pass WG message to controller.

Adding and Deleting Tag

• Add Single Tag or Random tags

Input *123456# (or Master Code) → 19 * UUUUU * 00001 # → Present the tag(s) with Controller (single tag or random numbered cards one by one) → Done
[e.g.] 2 readom cards with user addresses No. 100 and No. 101:

Access programming mode → 19 * 00100 * 00001 # → Present the tags one by one → Done

• Add the Sequential tags

Input *123456# (or Master Code) → 19 * UUUUU * QQQQ # → Present the tags (Present the tag with the **lowest number** first.) → OK

[e.g.] User Address NO.101 to NO.120 have 20 pcs of sequential tags:(62312~62332) :

Access programming mode → 19 * 00101 * 00120 # → Close Tag into RF Area(only use the tag **NO.62312**) → OK

• Delete a Single Tag

Input *123456# (or Master Code) → 10 * SSSSS 9 EEEEE #

[e.g.] Delete User Address: 00058

Access programming mode → 10 * 00058 9 00058 #

• Delete a batch of Tags

Input *123456# (or Master Code) → 10 * SSSSS 9 EEEEE #

[e.g.] Delete User Address: 00101~00245

Access programming mode → 10 * 00101 9 00245 #

• Delete All Tags

Input *123456# (or Master Code) → 29 * 29 * #

Tag Information



Programming

A. Entering and Exiting Programming Mode

• Entering

Input *123456# or *PPPPPP#

[e.g.] The Default Value= 123456, if already changed the Master Code= 876112, input *876112# → Access programming mode

• Exiting

Input * #

• Changing the Master Code

Access programming mode → 09 * PPPPPRRRRR # [Input the 6-digit new master code twice.]

[e.g.] If want to changing the Master Code= 876112, input *123456# → 09 * 876112876112 #

B. Changing the Node ID of Reader

Access programming mode → 00 * NNN * MMM * AAA #

[NNN= Node ID: 000~254; MMM=AR-331(E/EF)Door NO.:1~255; AAA=WG Reader Door NO.:1~255

C. Anti-pass-back

Usually, anti-pass-back is commonly applied to parking areas in order to prevent from multi-entry with one card at a time, or somewhere wants to monitor not only the access but also exit condition.

• Enable device

Access programming mode → 20 * U * DDD # U= Enable target unit(0=AR-331(E/EF),1=Reader) [Please refer to function default value for details.]

[e.g.] If the **AR-331(E/EF)** set to **exit reader**, **WG Reader** set to **access reader**.

Access programming mode → 20 * 0 * 128 # → 20 * 1 * 192 # [Please refer to function default value for details.]

• Enable card user

Access programming mode → 26 * SSSSS * EEEEE * P # SSSSS= starting user address; EEEEE= ending user address [P=0 Enable/ P=1 Disable/ P=2 Reset]

[e.g.] User address from 00152 to 00684 enable the anti-pass-back function: 26 * 00152 * 00684 * 0 #

D. Auto Open Zone

Door will keep opening after first man flashing card. When the reader is stand-alone, supporting only 16 sets of auto-open zone by device setting. Auto-open zone can extend up to unlimited sets by Networking.

• Enable/Disable auto open zone

Access programming mode → 20 * U * DDD # U= Enable target unit(0=AR-331(E/EF),1=Reader) [Please refer to function default value for details.]

[e.g.] If the **AR-331(E/EF)** set to **Enable aut open zone**.

Access programming mode → 20 * 0 * 004 # [Please refer to function default value for details.]

• Enable/Disable auto open door without presenting card

Access programming mode → 24 * U * DDD # U= Enable target unit(0=AR-331(E/EF),1=Reader) [Please refer to function default value for details.]

[e.g.] If the **WG Reader** set to **Enable aut open door without presenting card**.

Access programming mode → 24 * 1 * 128 # [Please refer to function default value for details.]

• Setting up access time

Access programming mode → 08 * MW * NN * HHMMhhmm * 7123456H # [M=AR-331(E/EF); W=Reader(0=disable,1=enable); NN: 16 sets of auto-open zone (NN=00~15); HHMMhhmm=Starting time to ending time; 7123456H= 7 days of week + Holiday (F= 0: disable; 1: enable)]

[e.g.] AR-331(E/EF)(**without WG reader**), to set second time zone which could be passed only at 9:30am to 4:20pm on Mon, Wed and Fri.

Access programming mode → 08 * 10 * 02 * 09301620 * 01010100 # → setting is completed

E. Lift control

Connect with **AR-401RO16B** to control floors which the user will be able to access. [BAUD9600]

• Single floor

Access programming mode → 27 * UUUUU * LL #

UUUU=User Address LL=Floor number (01~64 floor)

[e.g.] User address NO. 45 only can reach the elevator to the 24th floor: 27 * 00045 * 24 #

• Multi floors

Access programming mode → 21 * UUUUU * G * LLLLLLLL #

[UUUUU=User address G: 8 sets of lift control (Input: 0~7) LLLLLLLL:

8 floors setting (L=0=Disable, L=1=Enable)

[e.g.] User address NO. 168 can reach only the 6th and 20th floor:

Access programming mode → 21 * 00168 * 0 * 00100000 #

→ 21 * 00168 * 2 * 00001000 # → OK (Please refer to floor chart as right.)

Please refer to below floor chart

Set (G)	Floor							
	L	L	L	L	L	L	L	L
0	8	7	6	5	4	3	2	1
1	16	15	14	13	12	11	10	9
2	24	23	22	21	20	19	18	17
3	32	31	30	29	28	27	26	25
4	40	39	38	37	36	35	34	33
5	48	47	46	45	44	43	42	41
6	56	55	54	53	52	51	50	49
7	64	63	62	61	60	59	58	57

F. Setting Up the Arming

• Conditions:

1. Arming is enabled
2. Alarm system connected

• Application:

1. **Door open too long:** Door is open longer than door relay time plus door close time.
2. **Force open** (Opened without a valid user card): Access by force or illegal procedure.
3. **Door position abnormal:** Arming is enabled and the power is suddenly off then on.

• Enable Arming status:

Standby Mode					
Card only		Card or Passcode		Card and Passcode	
Enable all devices	Enable particular device	Input 5 digit user address → Input 4 digit pass code → # → Input 4 digits arming code → * * # or * U #	Input 5 digit user address → Input 4 digit pass code → # → Input 4 digits arming code → * * # or * U #	Induct valid card → Input 4 digit pass code → # → Input 4 digits arming code → * * # or * U #	Induct valid card → Input 4 digit pass code → # → Input 4 digits arming code → * * # or * U #
Induct valid card → Input 4 digit arming code → * * #	Induct valid card → Input 4 digit arming code → * U # or #				
Enter Program Mode					
Enable all devices: Access programming mode → * * #		Enable particular device: Access programming mode → * * U #			

• Disable Arming status:

Standby Mode					
Card only		Card or Passcode		Card and Passcode	
Disable all devices	Disable particular device	Input 5 digit user address → Input 4 digit pass code → # → Input 4 digits arming code → * 9 # or * U #	Input 5 digit user address → Input 4 digit pass code → # → Input 4 digits arming code → * 9 # or * U #	Induct valid card → Input 4 digit pass code → # → Input 4 digits arming code → * 9 # or * U #	Induct valid card → Input 4 digit pass code → # → Input 4 digits arming code → * 9 # or * U #
Induct valid card → Input 4 digit arming code → * 9 #	Induct valid card → Input 4 digit arming code → * U # or #				

※ Factory default armingcode is: 1234. U=Reader unit (0=AR-331(E/EF), 1=WG Reader).

G. Adding / Deleting Fingerprint

• Adding

Access programming mode → 3 9 * F * UUUUU # Place your finger on the sensor

[F=1= Adding 1 Finger data; F=2= Adding 2 Finger data; UUUUU= User address]

How to add a finger data:

Adding 1 Fingerprint (By DO)		Bi	Di	Bi	Di	Bi	Di	Bi	Di	Bi	Di	Bi	Di	Bi	Di	Long Bi (OK)				
Adding 2 Fingerprint (By DO)		Bi	Di	Bi	Di	Bi	Di	Long Bi (OK)		Bi	Di	Bi	Di	Bi	Di	Bi	Di	Long Bi (OK)		
Adding 3 Fingerprint (By DO)		Bi	Di	Bi	Di	Bi	Di	Long Bi (OK)		Bi	Di	Bi	Di	Bi	Di	Bi	Di	Long Bi (OK)		Repeat Finger 2

※ If you hear continuous "beep..." sounds when you place finger on the sensor, please release your finger from the sensor.

• Deleting

Access programming mode → 3 9 * 0 * UUUUU #

UUUUU= User address

• Deleting All

Access programming mode → 3 9 * 9 * 99999 #

H. Enable/Disable Skip Finger/Tag

Access programming mode → 4 0 * F * NNNNN * EEEEE #

(Please consult detail command on page 8.)

NNNNN= starting user address

EEEE= ending user address

F= 1+3(Default Value)

Command Setting	Software Setting	Access Mode	Way
40 * 1 * NNNNN * EEEEE #	<input type="checkbox"/> Just fingerprint	FP first and then Tag	First + Then
40 * 3 * NNNNN * EEEEE #	<input type="checkbox"/> Just card control		
40 * 0 * NNNNN * EEEEE #	<input checked="" type="checkbox"/> Just fingerprint	FP only or Tag only	or
40 * 2 * NNNNN * EEEEE #	<input checked="" type="checkbox"/> Just card control		

I. Adding / Deleting Fingerprint

1. For dual-fingerprint sensor module version, capacitive sensor module is the only enabled way for enrolling FP.
2. For dual-fingerprint sensor module version, user just can select one of fingerprint sensor for identification and can't put two fingerprints to different sensor at the same time.
3. Extra WG keypad panel is needed for adding card or downloading data connected to PC.
4. Each finger need to be collected 1 times enrolling for AR-331(E/EF).

J. The process of FP identification

1. While attached a finger on biometric sensor, there is a beep sound for starting the scanner. Then, please don't move your finger until the AR-331(EF) makes another beep sound.
2. If there is a 8-beep sound after user gets access by FP, the FP data shall be reset by command 39*9*99999# under the programming mode.

Restoring Factory Settings

Reset all device parameters and user card data

- **Reset all device parameters and user card data:**

Use the command:

Access programming mode → 29 * 29 9 #

Use the Button on the PCB:

Press "IP Reset Button" of main board for few seconds, then IP and all device parameters will reset. (Reference to picture)

※ After reset, you will hear the long reminder sound, and wait until the sound disappears. Resupply the power to device will restore factory setting. please refer to [38 * DDD #] command to reopen.

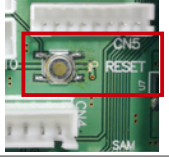

- **Reset all user card data:**

Access programming mode → 29 * 29 * #

Deleting All Fingerprint:

Access programming mode → 39 * 9 * 99999 #

Firmware Upgrade

Get the upgrade software from CCTV CORE or our distributor and run "UdpUpdater"

- **Execute the software** UDP Updater

The software is within CCTV CORE CD or Login the CCTV CORE web to downloads

- **Update the firmware**

[Please login the CCTV CORE web to download the new ISP

1. Input the Target Address and Port
2. [Load F/W] open the documents that have the new ISP Firmware
3. Click the new ISP Firmware and [Open] it
4. Click [Update Device] to start the firmware update
5. Till the screen shown [Firmware Update is Complete]

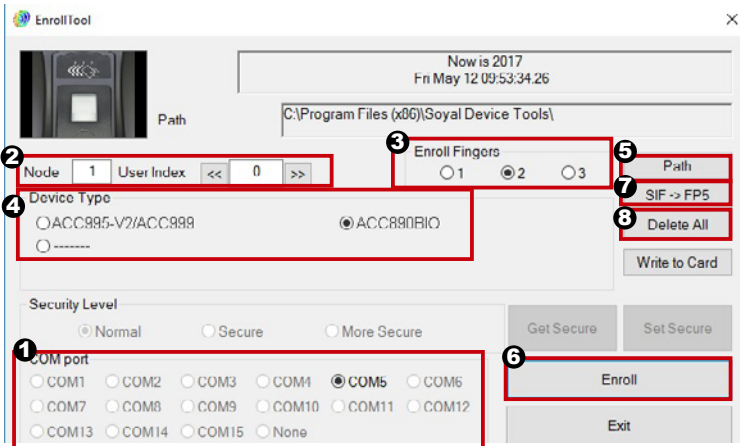
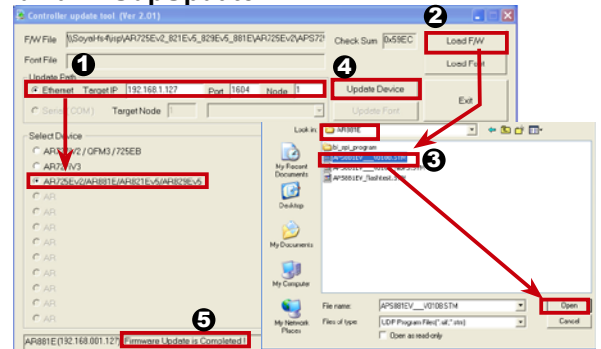

1. Select correct "COM Port".
2. Select "Node ID" of the device. Input "User Address".
3. Select the number of enrolled fingers in assigned path (1FP or 2FP per User).
4. Select the device type "AR-331(EF)".
5. Select "Save Path" in which will save fingerprint data.

6. Click "Enroll", follow pop-up picture and Status bar to enroll FP as below:
 Connect to Controller—> Place 1st finger 1st time to Finger sensor—> remove finger—> Place 1st finger 2nd time—> remove finger—> Place 2nd finger 1st time—> remove finger—> Place 2nd finger 2nd time—> Save FP data to File—> Registration Completed.

Transfer fingerprint format V9 -> V5

7. Click "SIF -> FP5", select old AR-331EF FP file format. SIF, the system will automatically generate new single FP file format. FP5 into 701Server folder. FP5 into 701Server folder.

Deleting fingerprint database on the device

8. Click "Delete All", all Fingerprint data from device will be deleted completely.

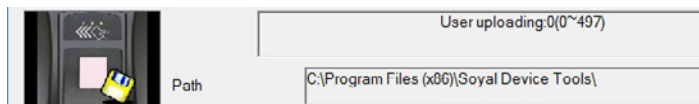

IP Setting

- Open your Web Browser and input factory default IP address: <http://192.168.1.127>

If the IP address of AR-331(E/EF) has changed We must enter the new IP address.



- Page menu

[Current State](#) ← Monitor the on-line computer

[Network Setting](#) ← IP Setting

[User Password](#) ← Change the Log-in information

- Current State

Online Status is able to monitor and show which computer is linking on Ethernet Module

Device Name	Type	IP address	Subnet mask	Gateway	DHCP
CONTROLLER	Ethernet	192.168.1.127	255.255.255.0	192.168.1.254	<input type="checkbox"/>

Current IP address of the AR-331(E/EF)

- Log-in User Password

When you choose the "Networking Setting" or "User Password" at first.

Log-in window will pop out and please input

※ At the Factory Default

User name: admin

Password: No as default value, so please just press "OK" to log-in

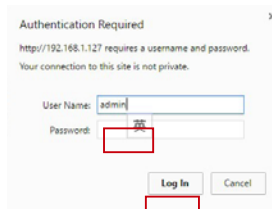

- Networking Setting

You will find initial IP Address 192.168.1.127 and check MAC Address is the same as sticker on Ethernet Module device. Please revise IP address you want, and then click "Update" button. After updating the IP, please re-connect the Web Browser by new IP address.

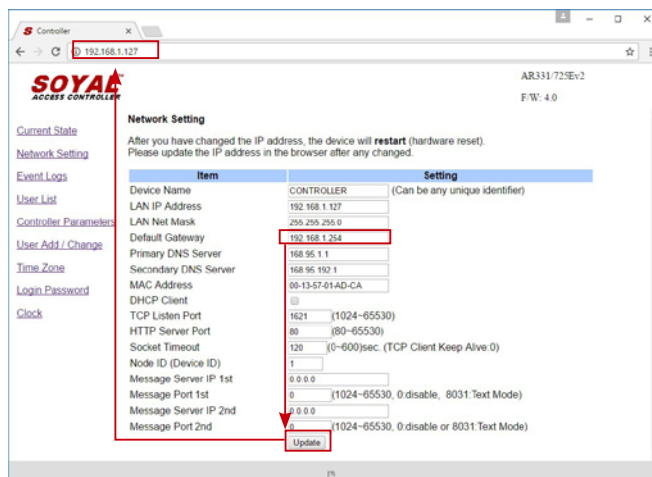

- User Password

Change the log-in password to lock the IP setting of Ethernet Module.

The password composes of 10 characters at most, it can be either A~Z or 0~9.

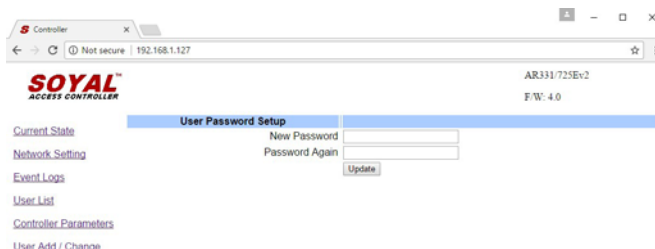

Command List (By WG Keyboard)

Function	Command	Exposition
Entering programming mode	* PPPPPP #	PPPPPP: Master Code, (Default value: 123456)
Exiting programming mode	* #	
Exiting programming mode and enabling all device into arming status.	* * #	Including AR-331(EF), WG Reader
Enabling each device into arming status.	* * U #	U= Enable target unit (0=AR-331(EF) , 1=WG Reader)
Node ID setting	00 * NNN * MMM * AAA #	NNN=Node ID,(001~254) MMM=AR-331(EF) Door Number,(001~255) AAA=WG Reader Door Number,(001~255)
IP Address assign (Must power reset)	01 * 0 * CCCCCCCCCC #	default value = 192.168.1.127 CCCCCCCCCCCC = 192168001127 If set to 000.000.000.000 will enable DHCP otherwise will disable DHCP
	01 * 1 * 255255255000 #	Netmask
	01 * 2 * 192168001254 #	Gateway assign
Door relay time setting	02 * U * TTT #	U= Enable target unit (0=AR-331(EF) , 1=WG Reader) TTT=Door relay time 000 (Output constantly) 001~600= 1-600 Sec. ; 601~609=0.1~0.9Sec.
Alarm relay time setting	03 * TTT #	TTT=Alarm relay time ; 000 (Output constantly) 001~600= 1~600 Sec.
Arming delay time setting	05 * TTT #	Base on second, range: 001~255
Alarm delay time setting	06 * TTT #	Base on second, range: 001~255
Master card setting	07 * SSSSS * EEEEE #	SSSSS-EEEE=00000~15999 SSSSS= starting user address; EEEEE= ending user address
Auto-open zone setting	08 * MW * NN * HHMMhmm * 7123456H #	M=AR-331(EF); W=WG Reader (0=disable; 1=enable) NN= 16 sets of auto-open zone (Range: 00~15) HHMMhmm=staring time to ending time (e.g.: 08301200=08:30 to 12:00) 7123456: 7 days of week -Sun/Mon/Tue/Wed/Thu/Fri/Sat (Input value: 0=disable; 1=enable) H: Holiday (Input value: 0=disable; 1=enable)
Master code settings	09 * PPPPPRRRRR #	PPPPPP= New master code RRRRRR= Repeat the new master code
Suspend or delete tags	Suspend : 10 * SSSSS * EEEEE # Delete : 10 * SSSSS 9 EEEEE #	* :Suspend 9 :Delete SSSSS= starting user address; EEEEE= ending user address
Recover tag	11 * SSSSS * EEEEE #	SSSSS= starting user address; EEEEE= ending user address
Setting up Card or PIN mode by user address	12 * UUUUU * PPPP #	UUUUU= user address; PPPP=4-digit individual PWD (Access mode: Card or PIN)
Arming output setting	14 * TTT #	Base on 1ms, range:1~255, default value=10, Input 0= Timeless
Duress code setting	15 * PPPP #	PPPP= 4-digit PWD (0001-9999) Default value : 4321
Arming PWD setting	17 * PPPP #	PPPP= 4-digit PWD (0001-9999) Default value : 1234
Enabling or Disabling into arming status	Card+NNNN #	NNNN : Arming PWD
Enabling or Disabling each device into arming status.	Card+NNNN * U #	U= Enable target unit (0=AR-331(E/EF), 1=WG Reader)
Enabling all device into arming status.	Card+NNNN * * #	
Disabling all device into arming status.	Card+NNNN * 9 #	
Door open waiting time	18 * U * TTT #	U= Enable target unit (0=AR-331(EF) , 1=WG Reader) TTT=Door open waiting time:001~600;default value:15 sec.
Set the card by induction	19 * UUUUU * QQQQQ #	UUUUU=user address QQQQQ=Card quantity(00001=Continuously inducting)
Reader additional setting	20 * U * DDD #	U= Enable target unit (0=AR-331(E/EF), 1=WG Reader) DDD=Function default value
Lift control setting: multi-doors	21 * UUUUU * G * LLLLLLL #	UUUUU= user address ; G=4 sets of lift control(0~3); LLLLLLL=8 assigned floor (F=0: Disable, 1: Enable)
AR-401RO16/ AR-401RO16B relay time setting	23 * MMM * TTT #	MMM=Node ID of lift controller TTT= relay time: 000~600=1~600 sec.
Factory setting	24 * U * DDD #	U= Enable target unit (0=AR-331(E/EF), 1=WG Reader) DDD : Function default value
Real time clock setting	25 * YYMMDDHHMMSS #	YYMMDDHHmmSS: Year/Month/Day/Hour/Min./Sec.

Command List (By WG Keyboard)

Function	Command	Exposition
Anti-pass-back (Enable user)	26 * SSSSS * EEEEE * P #	SSSS= starting user address; EEEEE= ending user address P=0=Enable; P=1=Disable; P=2=Initial
Lift control setting: single door	27 * UUUUU * LL #	UUUUU= user address ; LL : Floor number(01~64 floor)
Duress Function and Arming output setting	28 * FFF #	Arming output and Duress function: FFF= 008 (default value)
Delete all tag/Delete all tag + parameters setting	29 * 29 * # / 29 * 299 * #	
Same tag reading interval time	31 * TTTT #	Base on 10ms, range from 10 to 6000
Auto ring the clock alarm schedule	32 * SS * HHMMTT * 7123456H #	SS= 16 sets auto alarm schedule, range 0~15 HHMM= HH:MM (ex. 0830: Ring bell at 08:30) TT=Period of time to ring bell (Base on second, range 01~99 sec.) 7123456: 7 days of week -Sun/Mon/Tue/Wed/Thu/Fri/Sat (Input value: 0=disable; 1=enable) H: Holiday (Input value: 0=disable; 1=enable)
Holiday Setting	35 * MMDD * F #	MM= Month of year (01=Jan...10=Oct.) DD= Date of month (01=1st day of month) F= 0:Delete ; 1: Add
Enabling or Disabling into Full Access status	36 * MW #	M=AR-331(EF) ; W=WG Reader (0=disable; 1=enable)
RS485 port function setting (Needs to be restarted after setting)	37 * AB #	A=0:AR401RO B=0: 9600(default value) 1:Host (default value) 1: 19200 2:LED Panel 2: 38400 3:Printer 3: 57600
Biometric forms set (Needs to be restarted after setting)	38 * DDD #	002= 2000 Finger-Vein recognition 003= 9000 Optical / Capacitive fingerprint recognition 004= 200 Optical fingerprint recognition 008= 200 Capacitive fingerprint recognition 012= 200 Optical & Capacitive fingerprint recognition
Adding / Deleting Fingerprint	39 * F * UUUUU #	F= 1: Adding one finger data 2: Adding two finger data 3: Adding three finger data 0: Delete
Deleting All Fingerprint	39 * 9 * 99999 #	UUUUU= user address
En/Disable Skip Finger/Tag	40 * F * NNNNN * EEEEE #	First 40*1*NNNNN*EEEE# } setting a pair of command Then 40*3*NNNNN*EEEE# } Access mode: FP first and then Tag (Default Value) First 40*0*NNNNN*EEEE# } setting a pair of command Then 40*2*NNNNN*EEEE# } Access mode: FP only or Tag only NNNNN= starting user address;EEEEEE= ending user address

Function Default Value

20 * U * DDD #		※Default Value			
Function	Option		Value	Application	
Time Attendance	※0: Yes	1: No	001	Networking	
Auto Re-lock	※0: Disable	1: Enable	002	Networking/Stand-Alone	
Auto Open	※0: Disable	1: Enable	004	Networking/Stand-Alone	
When Access Mode is "Card and PIN", Readers can skip pressing PIN code.	※0: Disable	1: Enable	008	Networking/Stand-Alone	
Exit by Push Button	0: Disable	※1: Enable	016	Networking/Stand-Alone	
Enable force Open	※0: Slave	1: Mater	032	Networking	
As Access/Exit Reader	※0: Exit	1: Access	064	Networking	
Anti-pass-back	※0: Disable	1: Enable	128	Networking	
24 * U * DDD #		※Default Value			
Function	Option		Value	Application	
Enable Egress Beep Sounds	※0: Disable	1: Enable	001	Networking/Stand-Alone	
Skip Tag after FP Access	※0: Disable	1: Enable	002	Networking/Stand-Alone	
Enable Arm/Disarm Zone(62)	※0: Disable	1: Enable	008	Networking/Stand-Alone	
Reader and controller share the same door relay (only for reader)	0: Disable	※1: Enable	016	Networking/Stand-Alone	
Free Access Mode	※0: Disable	1: Enable	032	Networking/Stand-Alone	
Stop Alarm by...	※0: None	1: Push button/Door Closed	064	Networking/Stand-Alone	
Open door immediately without 1st card presented at auto open zone	※0: Disable	1: Enable	128	Networking/Stand-Alone	
28 * FFF #		※Default Value			
Function	Option		Value	Application	
Expiry User Access Trigger Alarm	※0:Disable	1:Enable	001	Networking/Stand-Alone	
Auto Reset Anti-pass on TZ61	※0:Disable	1:Enable	002	Networking/Stand-Alone	
Duress Function and Arming output setting	0:Wiegand output	※1: Arming and Duress	008	Networking/Stand-Alone	
RS-485	401RO16B:00	※HOST: 01	000 016	Networking/Stand-Alone	
	LED: 10	PRN: 11	032 048		



1141 Budapest, Fogarasi út 77. **1095 Budapest, Mester utca 34.**
Tel.: *220-7940, 220-7814, 220-7959, Tel.: *218-5542, 215-9771, 215-7550,
220-8881, 364-3428 Fax: 220-7940 216-7017, 216-7018 Fax: 218-5542
Mobil: 30 531-5454, 30 959-0930 Mobil: 30 940-1970, 30 959-0930

www.soyal.hu

E-mail: info@delton.hu Web: www.delton.hu

A dokumentáció a Delton szellemi tulajdona, ezért annak változtatása jogi következményeket vonhat maga után.
A fordításból, illetve a nyomdai kivitelezésből származó hibákért felelősséget nem vállalunk.
A leírás és a termék változtatásának jogát a forgalmazó és a gyártó fenntartja.