

Contents

1 Products

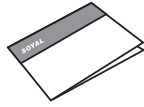

2 User Guide



3 Terminal Cables

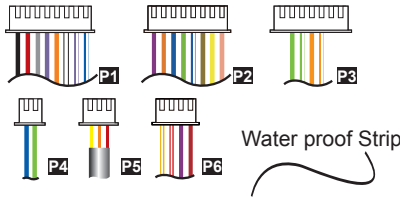

4 Tools



5 Optional



AR-821RB



AR-721RB
Digital Relay

Installation

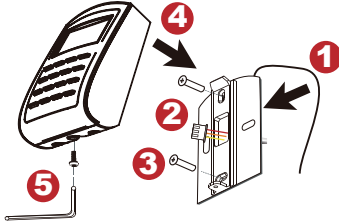

- Attach the water proof strip to the mounting plate.
- Pull the cables from the square hole of the mounting plate.
- Use a screwdriver to screw the base onto the wall.
- Connect the terminal cables to the body and attach the body to the mounting plate.
- Assemble the covers with the Allen key and screws (accessories supplied).
- Turn on the power, the LED will light and hear the beep sound, you will see "Ready" on LCD board.

Notice

- 1.Tubing:** The communication wires and power line should NOT be bound in the same conduit or tubing.
- 2.Wire selection:** Use AWG 22-24 Shielded Twist Pair to avoid star wiring ,CAT 5 cable for TCP/IP connection
- 3.Power supply:** Don't equip reader and lock with the same power supply. The power for reader may be unstable when the lock is activating, that may make the reader malfunction.
The standard installation: Door relay and lock use the same power supply, and reader use independent power supply.

Connector Table © More details please go download by www.soyal.com

Cable: P1

Wire Application	Wire	Color	Description
Lock Relay	1	Blue White	(N.O.)DC24V1Amp
	2	Purple White	(N.C.)DC24V1Amp
Lock Relay COM	3	White	(COM)DC24V1Amp
Door Contact	4	Orange	Negative Trigger Input
Exit Switch	5	Purple	Negative Trigger Input
Alarm Relay	6	Gray	DC24V1Amp
	7	Thick Red	DC 12V
Power	8	Thick Black	DC 0V

Cable: P2

Wire Application	Wire	Color	Description
Beeper	1	Pink	Beeper Output 5V/100mA, Low
LED	2	Yellow	Red LED Output 5V/20mA, Max
	3	Brown	Green LED Output 5V/20mA, Max
Door Output	4	Blue White	Transistor Output Max. 12V/100mA (Open Collector Active Low)
Wiegand	5	Thin Green	Wiegand DAT: 0 Input
	6	Thin Blue	Wiegand DAT: 1 Input
WG Door Contact	7	Orange	Negative Trigger Input
WG Exit Switch	8	Purple	Negative Trigger Input

Cable: P3

Wire Application	Wire	Color	Description
TCP/IP Output	1	---	---
	2	---	---
	3	Orange White	Net - TX+
	4	Orange	Net - TX-
	5	Green White	Net - RX+
	6	Green	Net - RX-
	7	---	---

Cable: P4

Wire Application	Wire	Color	Description
RS-485 for Lift Controller	1	Thick Green	RS-485(B-)
	2	Thick Blue	RS-485(A+)

Cable: P5

Wire Application	Wire	Color	Description
Anti-Tamper Switch	1	Red	N.C.
	2	Orange	COM
	3	Yellow	N.O.

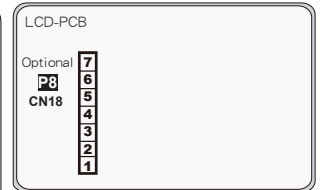
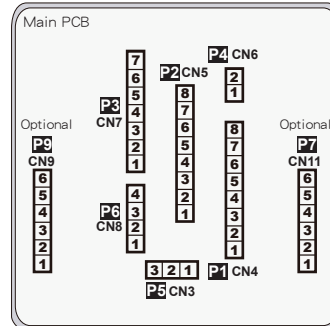

Cable: P6

Wire Application	Wire	Color	Description
Power	1	Red	DC 12V Output
Security trigger signal	2	Purple	Security trigger signal Output
Arming	3	Red White	Arming Output
Duress	4	Yellow White	Duress Output

Cable: P7 CN11 (Optional:Lift Control w/ AR-725L485) / P9 CN9

Wire Application	Wire	Color	Description
TTL Port	1	Black	DC 0V
	2	Yellow	TX
	3	White	TE
	4	Orange	RX
	5	Red	DC 5V
	6	---	---

Cable: P8 CN18 (Optional:HID ProxII RF Module)

Wire Application	Wire	Color	Description
HID RF Module	1	Orange	ANT 1
	2	Purple	ANT 2
	3	Black	DC 0V
	4	Red	DC 5V
	5	Blue	Wiegand DAT: 1 Input
	6	Green	Wiegand DAT: 0 Input
	7	White	--

Front Panel & Indicator

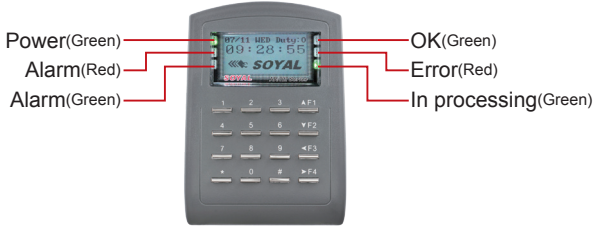

Attendance/Duty Functions		
	Press "1 time"	Press "2 times"
▲F1 Up	Duty on	Break out
▼F2 Down	Duty off	Break RTN
◀F3 Left	Overtime on	Go
▶F4 Right	Overtime off	Return
* Esc / Quit	# Enter / OK	

1. System will automatically exit from Programming Mode when inactivating for 30 seconds.
2. LED status indicates controller's mode and status.

OK (green) – blinking constantly when operates in Programming Mode

– or flashing an existed card in card learn mode, it comes 2 beeps warning and LCD panel displays "Same Card: user address / card number"

Error (red) – invalid card with 2 beeps warning and LCD panel displays "Card Number Err!"

– or in anti-pass-back mode, when violates the access, it comes one beep warning and LCD panel displays "Anti-pass Error!"

Arming (green) – arming on status

Alarm (red) – any abnormal condition occurs

3. Keypad will be locked up 30 sec. when constantly entering incorrect pin code or master code.

4. Maximum error in [ut of pin code and master code can be changed via the software 701Server (default: 5 times)

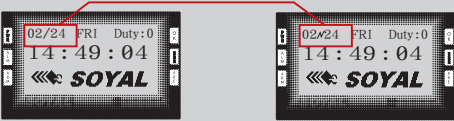

Networking : / and \ interactively flash between the Month and DAY.
[e.g.] 02/24 ↔ 02\24

Stand-alone : No flashing [e.g.] 02/24

(←Reference to picture)

Wiring Diagram

Connect to Electric Bolt

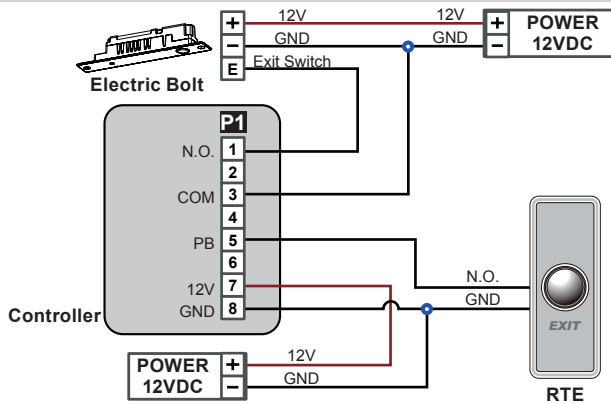

Connect to Magnet Lock

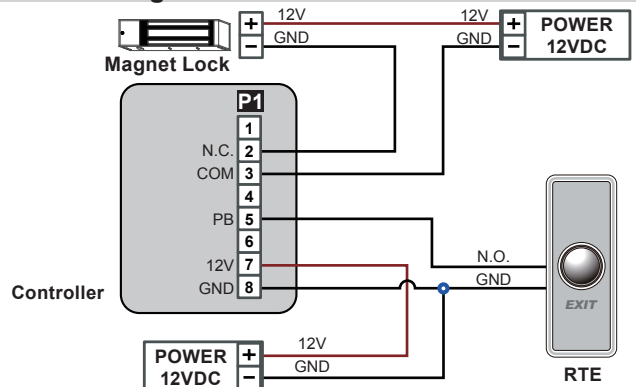

Connect to Electric Strike

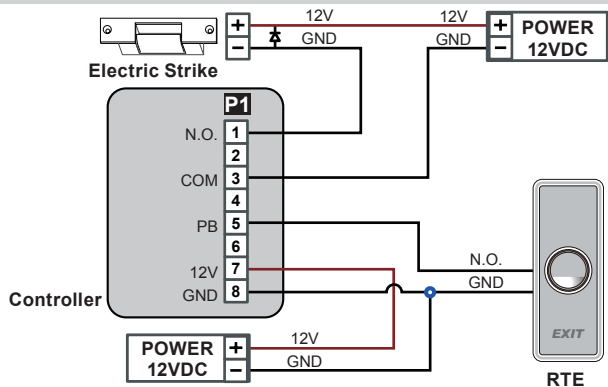

Connect to Door Contact

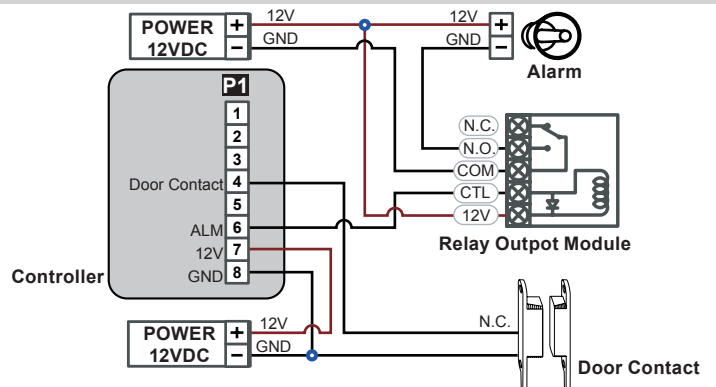

If any fire emergency, the people can escape by press a switch to open all doors

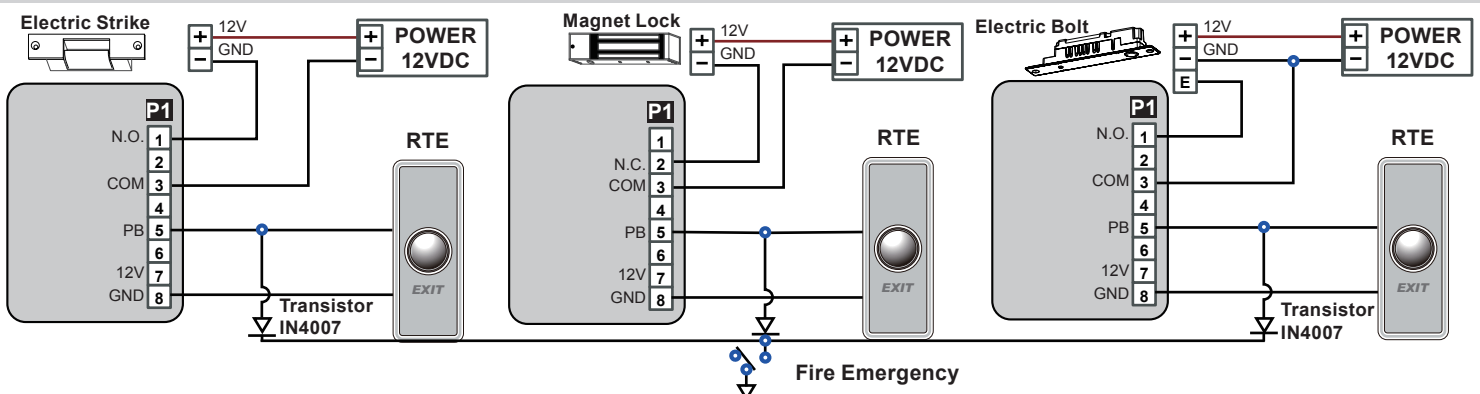

Strengthen security with AR-721RB

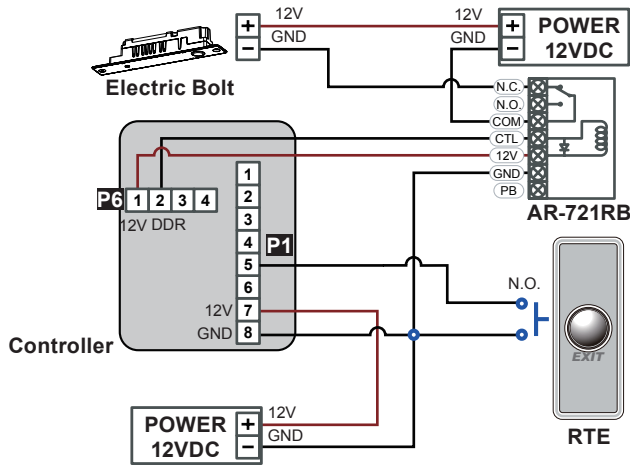

Connect to Reader

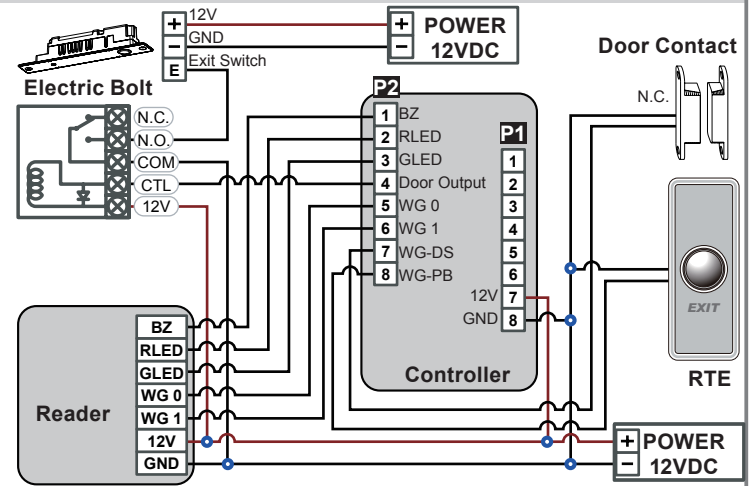

Adding and Deleting Tag

※ **User capacity: 16384 (00000~16383)**

• Adding Tag by Tag ID

Access programming mode → 1 Add/Delete → 1 Add → Card ID → Input 5-digit user address → Input Site Code → Input Card Code

• Adding Tag by RF Learn Function

Access programming mode → 1 Add/Delete → 2 Add → RF-Learn → Input 5-digit user address

→ Input Tag Units(pcs) → Close Tag into RF Area

※ If adding a batch of **Sequential** tags, please input Tag Units(pcs) in the quantity of the tags and present the tag with the **lowest card code** to the access controller.

• Deleting User Address

Access programming mode → 1 Add/Delete → 5 Delete → Addr → Input Starting address → Input Ending address

• Deleting Tag by Tag ID

Access programming mode → 1 Add/Delete → 6 Delete → ID # → Input Site Code → Input Card Code

• Setting up the access mode

Access programming mode → 2 User Setting → 2 Access Mode → Input User Address → 0: Invalid; 1: Card ; 2: Card or PIN; 3: Card & PIN

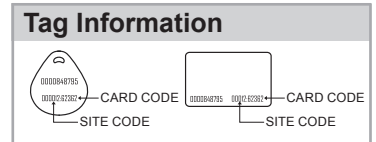

Programming

A. Keyboard Lock/ Unlock

• Lock/ Unlock

Press * and #, and at the same time to lock keyboard.

Press again to unlock.

B. Entering and Exiting Programming Mode

• Entering

Input *123456# or *PPPPPP#

[e.g.] The Default Value= 123456. If already changed the Master Code= 876112, input *876112# → Access programming mode
P.S.If entering no instruction within **30 sec.**, it will automatically leave the programming mode.

• Exiting

Press the * repeatedly → 6 Quit or 7 Quit and Arming (Please refer to alarm / arming setting)

• Changing the Master Code

Access programming mode → 5 Tools → 2 Master Code → Input the 6-digit new master code → Succeeded

C. Initial setup

• Language Setting

Access programming mode → 5 Tools → 1 Language → 0 EN → Succeeded → Initial system...

• Node ID of Reader Setting

Access programming mode → 3 Parameters[1] → 1 Node ID
→ Input New Node ID : 1~254 (default value:001) → Main Door Number : 0~255 → WG1 Door Number : 0~255 → Show UID (0=No,1=WG,2=ABA,3=HEX) → Enable DHCP(0:No,1:En,2=Exit) → Succeeded

D. PIN Code

• Access programming mode → 2 User Setting → 1 Password → Input 5-digit user address → Input 4-digit PIN (0001~9999) → Succeeded
Or via 701Client set it on Users screen

E. Setting up the alarm / arming

• **Conditions:** 1. Arming enabled 2. Alarm system connected

• Application:

- 1. Door open too long:** Door is open longer than door relay time plus door close time.
- 2. Force open** (Opened without a valid user card): Access by force or illegal procedure.
- 3. Door position abnormal:** When power is off and then on, reader on arming before power off.

F. Enable Voice Module (supporting version : F/w Ver 3.02 or later)

• Hardware setting

Access programming mode → 5 Tools → 5 Ext. Comm Port → 2 Voice

• Software Setting

701 Server  or 

• Step 1. Click "Read."

Step 2. Select "Card Reader" in RS485-2 section.

Step 3. Click "Write" to finish the setting.

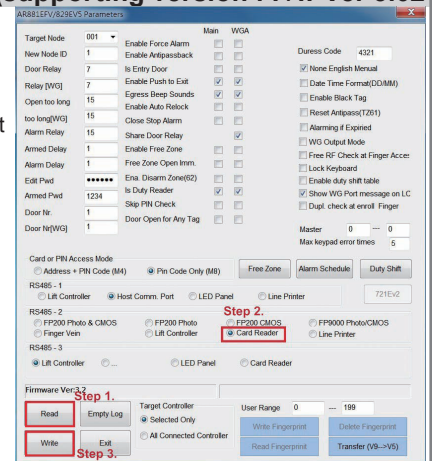

E. Setting up the alarm / arming

- Enable/Disable the arming status:

Standby Mode		Card or PIN	Card and PIN
Card only			
Open the door	No open the door	Input user address → Input 4 digits individual PWD → # → Input 4 digits arming PWD → #	Present the tag to reader → Input 4 digits individual PWD → # → Input 4 digits arming PWD → #
Present the tag to reader → Input 4 digits arming PWD → #	* → Input 4 digits arming PWD → Present the tag to reader		
Access Programming mode			
Enable: Access programming mode → 7 Quit & Arming		Disable: Access programming mode → 6 Quit	

Restoring Factory Settings

Reset all device parameters and user card data

- **Reset all device parameters and user card data:**
Access programming mode → **4** Parameters2 → **9** Factory Reset → **0** : System Param ;

1 : User Setting ; 2 : System & User

- **Reset IP Setting:**

When the device's power is on, press the [RESET] button the main board until the ERR (Red) LED of screen lights up. (Reference to picture)

※ After operation as above, you will hear the long reminder sound, and wait until the sound disappear then reset the power of the controller, the device will restore factory setting.

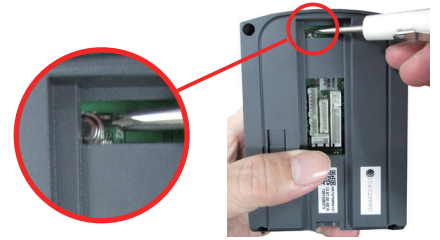

Manu Tree

1. Add/ Delete

1. Add > Card ID
2. Add > RF Learn
3. Suspend > Address
4. Suspend > ID #
5. Delete > Address
6. Delete > ID #
7. Recover > Address
8. Recover > ID #
9. Antipass Group

2. User Setting

1. Password
2. Access Mode
3. Extend Options
4. Single Floor
5. Multi Floor

3. Parameters[1]

1. Node ID
2. OnOff OpenZone
3. Door Relay Tm
4. Door Close Tm
5. Alarm Relay Tm
6. Alarm Delay Tm
7. Arming Delay Tm
8. Arming PWD

4. Parameters[2]

1. Auto Relock
2. Egress(R.T.E)
3. Miscellaneous
4. Force Open
5. Close & Stop
6. Anti-pass-back
7. Duress Code
8. Password Mode
9. Factory Reset

5. Tools

1. Language
2. Master Code
3. Master Range
4. Terminal Port
5. Ext.Comm Port
6. Open Time Zone
7. Informations
8. Clock Setting
9. Daily Alarm

6. Quit

7. Quit & Arming

IP Setting

- **Open your Web Browser and input factory default IP address: http://192.168.1.127**

If the IP address of AR-727 (H-V5) has changed We must enter the new IP address.

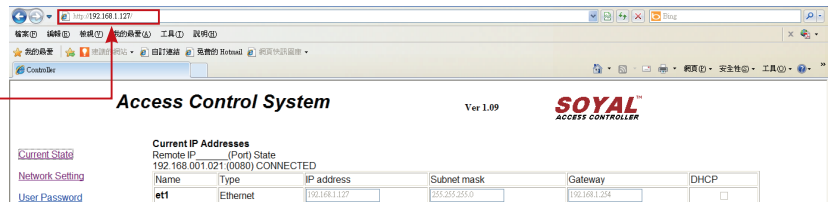

- **Log-in User Password**

When you choose the "Networking Setting" or "User Password" at first. Log-in window will pop out and please input

※ At the Factory Default

User name: admin

Password: No as default value, so please just press "OK" to log-in



- **Networking Setting**

You will find initial IP Address 192.168.1.127 and check MAC Address is the same as sticker on Ethernet Module device. Please revise IP address you want, and then click "Update" button. After updating the IP, please re-connect the Web Browser by new IP address.



- **User Password**

Change the log-in password to lock the IP setting of Ethernet Module.

The password composes of 10 characters at most, it can be either A~Z or 0~9.

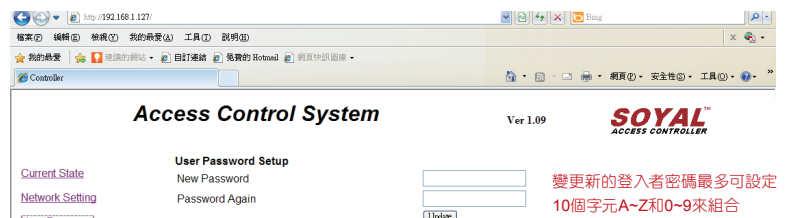



1141 Budapest, Fogarasi út 77. **1095 Budapest, Mester utca 34.**
Tel.: *220-7940, 220-7814, 220-7959, Tel.: *218-5542, 215-9771, 215-7550,
220-8881, 364-3428 Fax: 220-7940 216-7017, 216-7018 Fax: 218-5542
Mobil: 30 531-5454, 30 939-9989 Mobil: 30 940-1970, 20 959-0930

www.soyal.hu

E-mail: info@delton.hu Web: www.delton.hu